

Plan
14963010003 Toilet paper double holder

PRODUCT

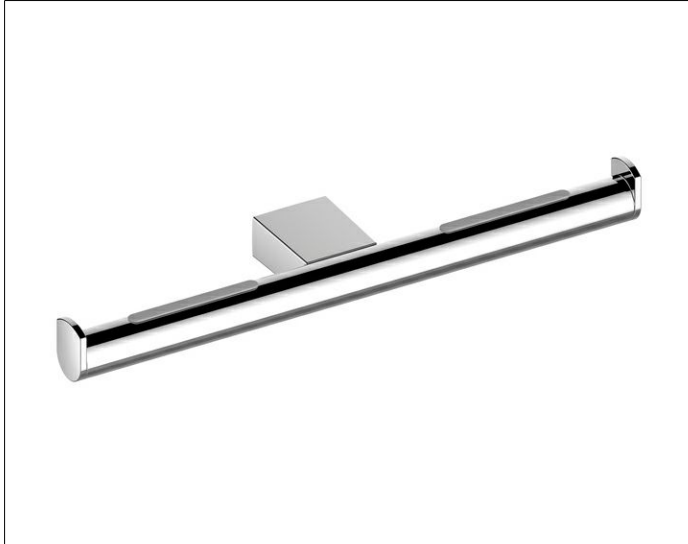

DRAWING

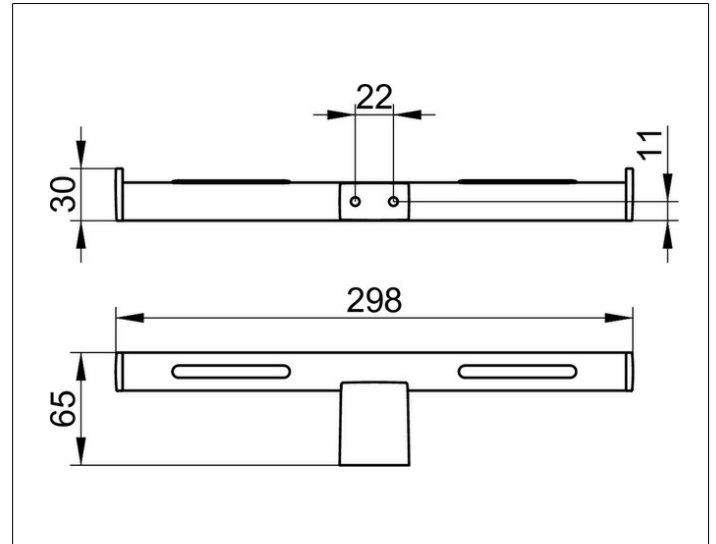

PRODUCT ATTRIBUTES

for roll width of 100/120 mm

SURFACE

chrome-plated

NOTE

SPECIFICATIONS

KEUCO PLAN Toilet paper double holder, 14963010003
 highgloss chrome-plated toilet paper double holder for roll width of 100/120 mm,
 with integrated roller brake made of thermoplastic, Elastomer plastic,
 in an aesthetic, functional design,
 Width: 298 mm, total projection without paper roll 65 mm,
 tube diameter 22 mm,
 the toilet paper double holder is mounted concealed,
 delivery incl. corrosion-free fastening material