

Edition 11

51120010100 Bath tub mixer DN 15

**PRODUCT**



**DRAWING**

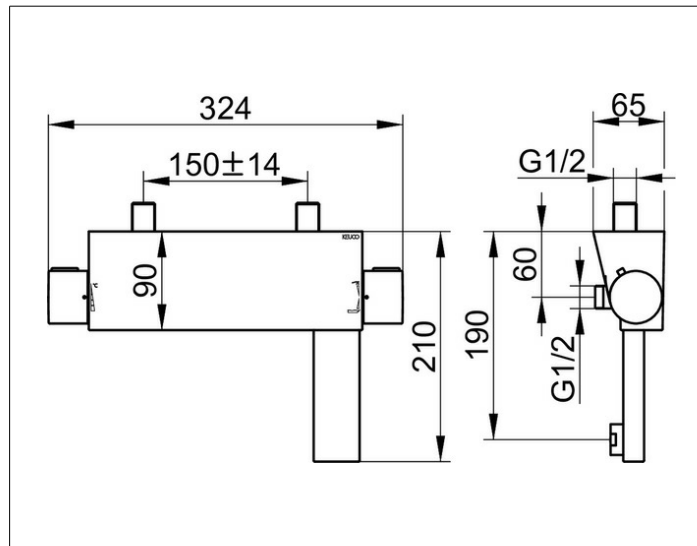

**PRODUCT ATTRIBUTES**

exposed  
 ceramic stop valve and diverter,  
 cartridge mixer with ceramic sealing gaskets,  
 shower outlet connection DN15  
 (restricted flow rate for handshower 15 l/min),  
 with backflow preventer,  
 gauge 150 +/- 14 mm,  
 suitable for combination boilers,  
 aerator M 28x1

**SURFACE**

chrome-plated

**SPECIFICATIONS**

KEUCO EDITION 11 single lever bath mixer DN 15 51120010100  
 high-gloss chromed single lever bath mixer DN 15  
 in clear-cut design and clear geometric shapes for surface mounting, high-  
 quality cartridge with ceramic discs  
 Hose connection DN 15, flow rate limited to 12 min l /,  
 Protected against backflow  
 Aerator M28 x 1  
 suitable for water heater  
 Height 65 mm, width 324 mm  
 maximum radius 210 mm  
 Gauge 150, tolerance class + / - 14 mm  
 DVGW-test applied